

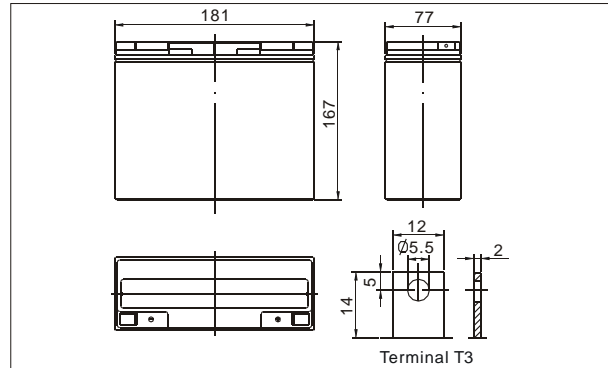

● **Outer dimensions (mm)**



The CHIWAY sealed lead-acid rechargeable battery (VRLA battery) is leak-proof and maintenance free. The Superiority of VRLA battery is derived from its uniquely efficient oxygen recombination technology. The oxygen evolved from the positive plates diffuses through the micro porous glassfiber mat to the negative plates where it is changed back to water by recombination reaction, eliminating the need for water addition. The result is a maintenance free battery.

● **Battery Construction**

| Component    | Positive plate | Negative plate | Container | Cover | Safety valve | Terminal | Separator  | Electrolyte   |
|--------------|----------------|----------------|-----------|-------|--------------|----------|------------|---------------|
| Raw material | Lead dioxide   | Lead           | ABS       | ABS   | Rubber       | Copper   | Fiberglass | Sulfuric acid |

● **General Features**

- Absorbent Glass Mat (AGM) technology for efficient gas recombination of up to 99% and freedom from electrolyte maintenance or water adding.
- Not restricted for air transport-complies with IATA/ICAO Special Provision A67.
- UL-recognized component.
- Can be mounted in any orientation.
- Computer designed lead, calcium tin alloy grid for high power density.
- Long service life, float or cyclic applications.
- Maintenance-free operation.
- Low self discharge.

● **Application**

- Electric powered vehicles
- Golf cars and buggies
- PDA equipment as laptop computer,
- Camera, phone sets, medical sets
- Power tools, Lawn mowers, vacuum cleaners
- Electric Powered Toys
- Wheel Chairs

● **Specifications**

|   |              |                    |
|---|--------------|--------------------|
| Nominal Voltage   |              | 12V                |
| Capacity (20 hr 25°C)                                     |              | 17Ah               |
| Design Life   |              | 3-5 Years          |
| Dimensions  | Length       | 181 mm (7.13 inch) |
|   | Width        | 77 mm (3.03 inch)  |
|   | Height       | 167 mm (6.57 inch) |
|   | Total Height | 167 mm (6.57 inch) |
| Approx. Weight  |              | 5.70Kg (12.57 lbs) |
| Capacity<br>25°C (77°F)                                   | 20 hr rate   | 17Ah               |
|   | 10 hr rate   | 15.81Ah            |
|   | 3 hr rate    | 14.45Ah            |
|   | 1 hr rate    | 10.2Ah             |
| Internal Resistance (Full charged Battery at 25°C (77°F)) |              | 16 mΩ              |

|   |          |                          |
|---|----------|--------------------------|
| Capacity affected by Temperature (20hr) | 40°C     | 102%                     |
|   | 25°C     | 100%                     |
|   | 0°C      | 85%                      |
|   | -15°C    | 65%                      |
| Self-Discharge at 25°C                  | 3 month  | Remaining capacity: 91%  |
|   | 6 month  | Remaining capacity: 82%  |
|   | 12 month | Remaining capacity: 65%  |
| Normal operating temperature            |          | 25°C ± 3°C (77°F ± 5°F)  |
| Operating temperature range             |          | -15°C ~ 50°C (5 ~ 122°F) |
| Float charging voltage (25°C)           |          | 13.6 to 13.8V            |
| Cyclic charging voltage (25°C)          |          | 14.5 to 14.9V            |
| Maximum charging current                |          | 6.8A                     |
| Terminal material                       |          | Copper                   |
| Maximum Discharge current               |          | 255A (5sec)              |

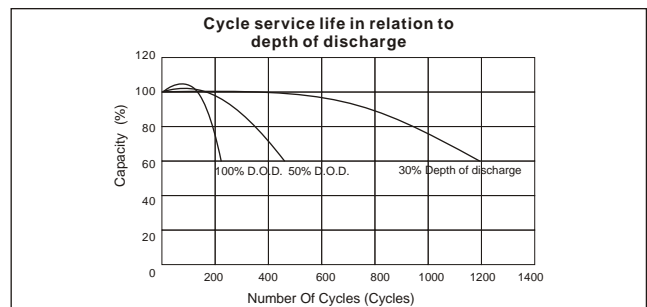
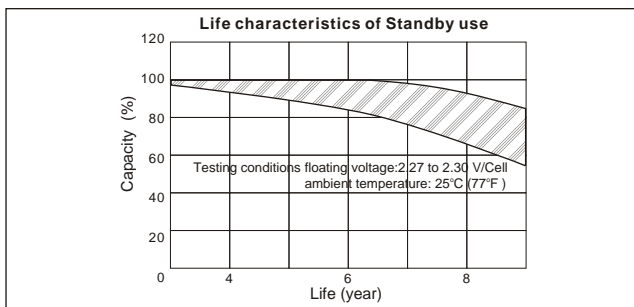
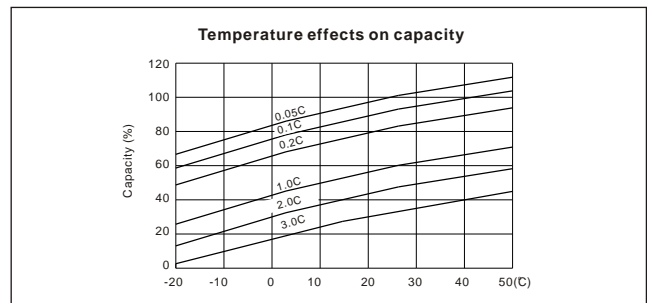
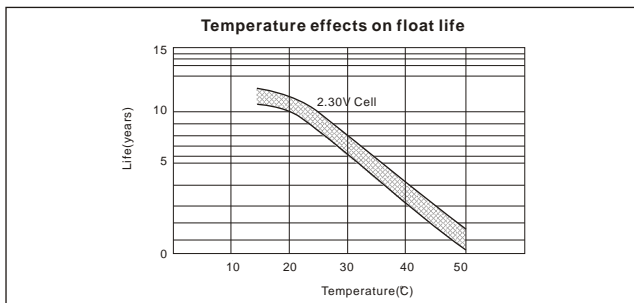
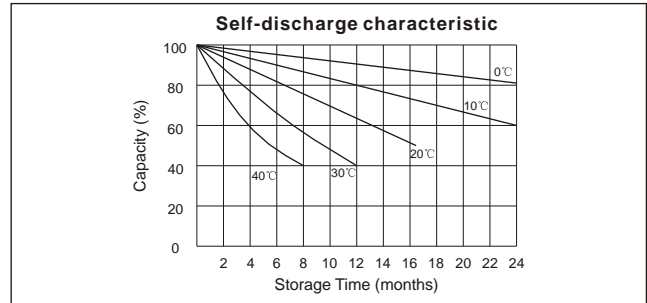
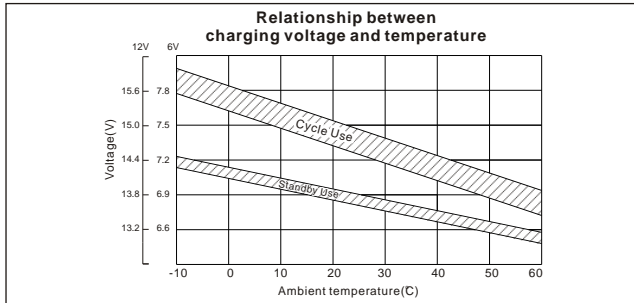
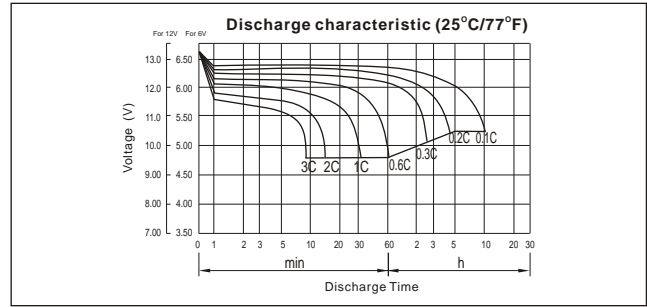
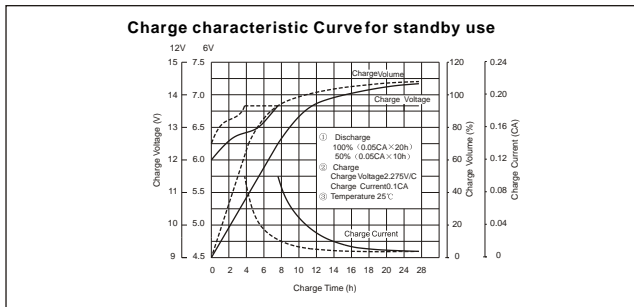

| F.V/Time | Constant Current Discharge Characteristics(Amperes, 25°C) |       |       |       |      |      |      |      | Constant Power Discharge Characteristics(Watts, 25°C) |       |       |       |    |      |       |       |
|----------|---|-------|-------|-------|------|------|------|------|---|-------|-------|-------|----|------|-------|-------|
|          | 5min  | 10min | 15min | 30min | 1h   | 3h   | 5h   | 10h  | 5min  | 10min | 15min | 30min | 1h | 3h   | 5h    | 10h   |
| 10.80V   | 42.6  | 40.5  | 18.7  | 10.63 | 4.53 | 2.98 | 1.70 | 0.85 | 539   | 357   | 152   | 92    | 48 | 32.0 | 18.02 | 10.34 |
| 10.50V   | 47.6  | 42.5  | 19.1  | 10.91 | 4.53 | 2.98 | 1.70 | 0.85 | 581   | 384   | 162   | 97    | 50 | 33.2 | 18.42 | 10.43 |
| 10.20V   | 54.4  | 43.1  | 19.7  | 11.19 | 4.68 | 3.12 | 1.70 | 0.85 | 626   | 411   | 172   | 102   | 51 | 34.6 | 18.59 | 10.48 |
| 9.60V    | 59.6  | 45.3  | 20.5  | 11.62 | 4.68 | 3.12 | 1.70 | 0.85 | 714   | 465   | 191   | 112   | 54 | 35.7 | 18.59 | 10.63 |

|                    |                     |                        |                      |                          |        |                      |         |
|--------------------|---------------------|------------------------|----------------------|--------------------------|--------|----------------------|---------|
| Packing Dimensions | 329*324*125mm       | Quantity Per Box       | 6 pcs                | Net weight Per Box       | 24.0kg | Gross weight Per Box | 24.8 kg |
| Splint             | Europe (1200*800mm) | Australia(1150*1100mm) | Standard(1100*950mm) | Nonstandard (1000*970mm) |        |                      |         |
| 20'DRY 8.5'        | 3.96k               |                        | 3.78k                |                          | 3.88k  |                      | 3.78k   |



**SHENZHEN CHIWAY BATTERY CO., LTD.** [www.chiway-battery.com](http://www.chiway-battery.com)  
 Jingyi Industrial Zone, NO.528 Jinbi Road, Pingshan Town, Longgang District, Shenzhen, China.  
 Tel: (+86-755) 8993 0038 8993 1028 Fax: (+86-755)8993 0306 E-mail : sales@chiway-battery.com