

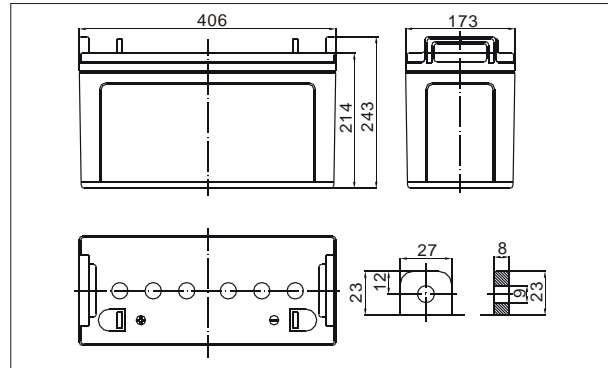

● Outer dimensions (mm)



The CHIWAY sealed lead-acid rechargeable battery (VRLA battery) is leak-proof and maintenance free. The Superiority of VRLA battery is derived from its uniquely efficient oxygen recombination technology. The oxygen evolved from the positive plates diffuses through the micro porous glass fiber mat to the negative plates where it is changed back to water by recombination reaction, eliminating the need for water addition. The result is a maintenance free battery.

● Battery Construction

Component	Positive plate	Negative plate	Container	Cover	Safety valve	Terminal	Separator	Electrolyte
Raw material	Lead dioxide	Lead	ABS	ABS	Rubber	Pb	Fiberglass	Sulfuric acid

● General Features

- Absorbent Glass Mat (AGM) technology for efficient gas recombination of up to 99% and freedom from electrolyte maintenance or water adding.
- Not restricted for air transport-complies with IATA/ICAO Special Provision A67.
- UL-recognized component.
- Can be mounted in any orientation.
- Computer designed lead, calcium tin alloy grid for high power density.
- Long service life, float or cyclic applications.
- Maintenance-free operation.
- Low self discharge.

● Application

- Alarm System
- Medical Equipment
- Cable Television
- Control Equipment
- UPS
- Communication Equipment
- Toys
- Emergency power System
- Power Tools
- Security System

● Specifications

Nominal Voltage		12V
Capacity (10 hr 25°C)		100Ah
Design Life		10 Years
Dimensions	Length	409 mm (16.1 inch)
	Width	176 mm (6.93 inch)
	Height	208 mm (8.20 inch)
	Total Height	225 mm (8.86 inch)
Approx. Weight		31Kg (68.2 lbs)
Capacity 25°C (77°F)	10 hr rate	100Ah
	3 hr rate	80Ah
	1 hr rate	65Ah
Internal Resistance (Full charged Battery at 25°C (77°F))		4.5 mΩ

Capacity affected by Temperature (20hr)	40°C	102%
	25°C	100%
	0°C	85%
	-15°C	65%
Self-Discharge at 25°C	3 month	Remaining capacity: 91%
	6 month	Remaining capacity: 82%
	12 month	Remaining capacity: 65%
Normal operating temperature		25°C ± 3°C (77°F ± 5°F)
Operating temperature range		-15°C ~ 50°C (5 ~ 122°F)
Float charging voltage (25°C)		13.6 to 13.8V
Cyclic charging voltage (25°C)		14.5 to 14.9V
Maximum charging current		30A
Terminal material		Pb
Maximum Discharge current		800A (5sec)

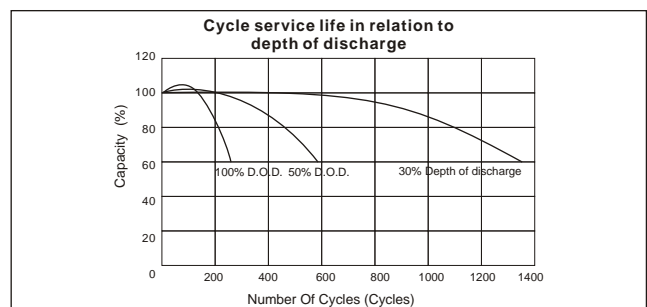
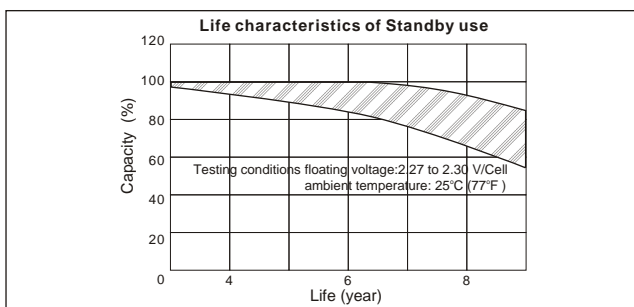
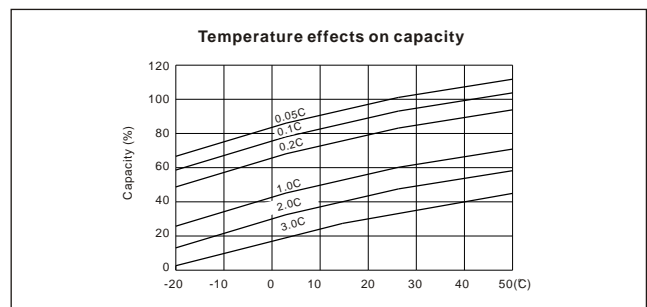
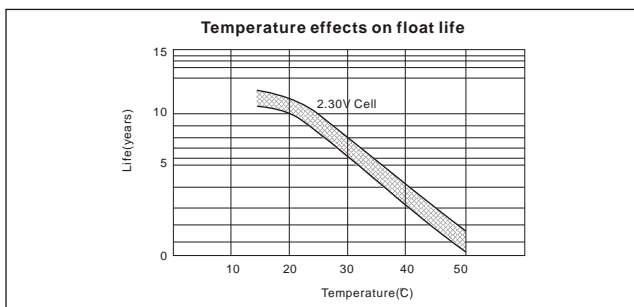
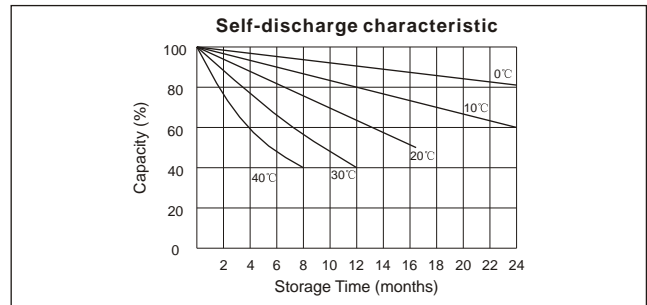
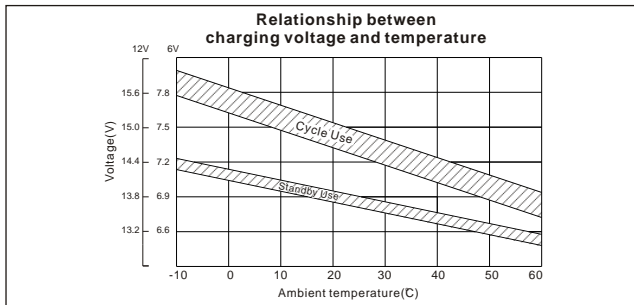
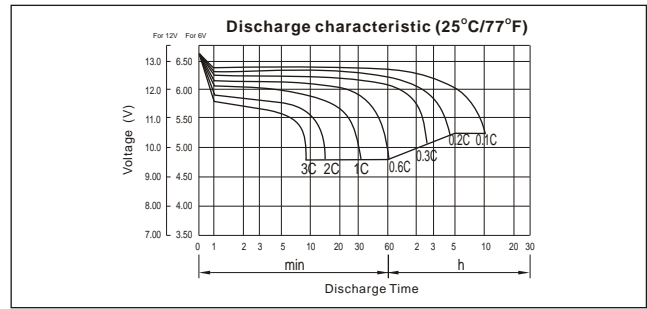
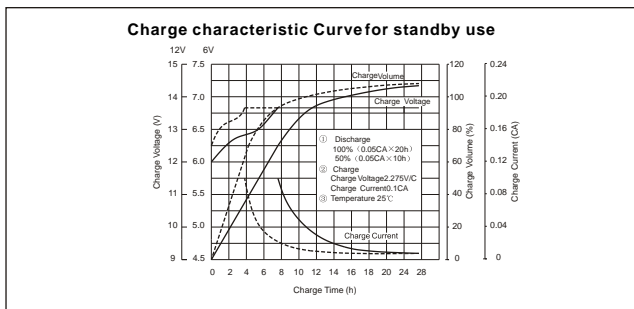

F.V/Time	Constant Current Discharge Characteristics(Amperes, 25°C)								Constant Power Discharge Characteristics(Watts, 25°C)							
	5min	10min	15min	30min	1h	3h	5h	10h	5min	10min	15min	30min	1h	3h	5h	10h
10.80V	266.0	190.9	144.0	88.0	62.0	25.00	16.80	10.00	2930.0	2060.6	1580.0	1000.0	710.0	290.0	195.0	119.4
10.50V	280.0	198.5	165.0	98.0	63.0	26.00	17.44	10.10	3080.0	2127.3	1627.3	1120.0	723.9	305.0	205.0	120.0
10.20V	300.0	204.5	175.9	108.0	64.0	26.50	17.80	10.20	3250.0	2193.9	1730.0	1230.0	736.1	310.0	208.0	120.6
9.60V	350.0	213.6	195.0	120.0	65.0	27.00	17.80	10.30	3800.0	2309.1	1750.0	1380.0	746.1	315.0	210.0	121.2

Packing Dimensions	433*200*250mm	Quantity Per Box	1 pcs	Net weight Per Box	31kg	Gross weight Per Box	31.5 kg
Splint	Europe (1200*800mm)	Australia(1150*1100mm)	Standard(1100*950mm)	Nonstandard (900*800mm)			
20'DRY 8.5'	396PCS		480PCS	480PCS	480PCS	480PCS	



SHENZHEN CHIWAY BATTERY CO., LTD.

Jingyi Industrial Zone, NO.528 Jinbi Road, Pingshan Town, Longgang District, Shenzhen, China.
Tel: (+86-755) 8993 0038 8993 1028 Fax: (+86-755)8993 0306 E-mail : sales@chiway-battery.com

www.chiway-battery.com